

LSA300

SIDE LOADING SEMI-AUTOMATIC CASEPACKER



Side loading semi-automatic case packer, suitable for the packaging of individual or bundled cartons into manually formed cases. The machine footprint is extremely compact and it is the ideal solution in case of space restrictions at the end of the line.

The Cartons/Bundles feeding is totally automatic.

The vertical Stacking station (with pre-stacking buffer), the commanded pusher and mobile hopper perform, with servo-motors, the automatic introduction in the formed Case.

The case has to be prepared (formed and partially sealed) in front of the Hopper. Once filled, the case is rotated from the case tilter and placed on the output inclined roller conveyor.

Finally, the case has to be closed and taped

manually by Operator. Size change-over takes only a few minutes to perform and does not require the use of any tools. Fine adjustments can be done through digital indicators.

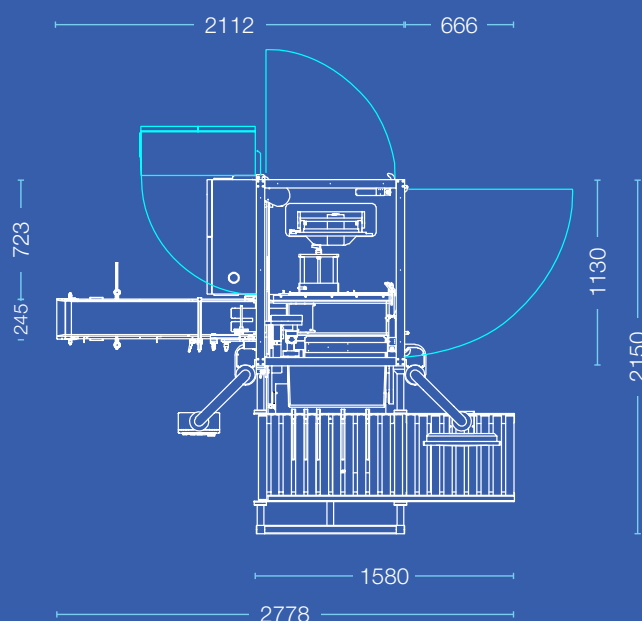

OPTIONAL:

- Pusher concealing **System for Aggregation Inspection®**
- Formed cases Buffer and automatic case feeding by the case tilter
- Exit Belt and Automatic Case Print or Labelling Station
- Pusher Inspection **Clear System®** allows to free the inspection area and allows the camera to inspect a full layer into the mobile hopper: the pusher structure is completely lifted up (European Patent N° WO 2015/107452 A1):
 - The inspection is performed in the hopper, the last step before the introduction of the full

- cartons composition into the formed case
 - The distance between the camera lens and the layer is always the same, regardless of format size and the number of layers: the camera doesn't need the autofocus functionality
 - The camera position doesn't need to be changed by format
- The inspection area is pre-determined as the maximum area, the camera can acquired
- The vision system can set the capture grid by format
- Every Vision/Aggregation system can be integrated in the Machine (all vision system HW is integrated in the machine cabinet)

TECHNICAL DATA	
COMPRESSED AIR	6 bar
AIR CONSUMPTION	120 NI/min
INSTALLED POWER	5,5 Kw
MAX SPEED	Up to 5 cases/min
CARTONS/BUNDLE DIMENSIONS	
A	30÷300
B	15÷200
C	65÷200
CASES DIMENSIONS	
A	150÷550
B	110÷400
C	75÷400

